

# DESIGN OF A SPATIO-TEMPORAL 3-D ELLIPSOIDAL PHOTOCATHODE LASER SYSTEM FOR THE HIGH BRIGHTNESS PHOTOINJECTOR PITZ\*

T. Rublack<sup>#</sup>, J. Good, M. Khojayan, M. Krasilnikov, F. Stephan, DESY, Zeuthen, Germany  
 I. Hartl, S. Schreiber, DESY, Hamburg, Germany  
 A. Andrianov, E. Gacheva, E. Khazanov, S. Mironov,  
 A. Poteomkin, V. V. Zelenogorskii, IAP/RAS, Nizhny Novgorod, Russia  
 E. Syresin, JINR, Dubna, Russia

## Abstract

Minimized emittance is crucial for successful operation of linac-based free-electron lasers. Simulations have shown that 3-D ellipsoidal photocathode laser pulses are superior to the standard Gaussian or cylindrical laser pulses in this manner. Therefore, in collaboration with the Joint Institute of Nuclear Research (JINR, Dubna, Russia) and the Photo Injector Test facility at DESY, Zeuthen site (PITZ), a prototype laser system capable of producing spatio-temporal 3-D ellipsoidal pulses has been constructed at the Institute of Applied Physics of the Russian Academy of Science (IAP / RAS, Nizhny Novgorod, Russia). It is expected to receive the finalized prototype at PITZ within this year.

The laser system to create such 3-D ellipsoidal laser pulses will be introduced. Also the procedure of pulse shaping will be described in detail.

## INTRODUCTION

The operation of modern free-electron lasers (FELs) necessitates high brightness electron bunches with small energy spread. As the electron beam parameters along the beam line depend strongly on initial conditions at the photocathode, a minimized emittance is crucial for a successful FEL operation. An important parameter crucial for the initial conditions is given by the characteristics of the cathode laser.

In the following paragraphs the influence of different laser pulse parameters on the initial electron beam quality will be briefly discussed. While some of the parameters are well known due to previous experience, others have to be simulated and/or empirically determined.

If the photon energy is below the vacuum energy level (where an electron is free) of the photocathode material, it is impossible to generate emission of free electrons with single photon excitation [1]. The vacuum energy level is defined as the sum of the electron affinity and the band gap energy for semi-conductors, or equivalently as the work function in metals.

Due to scattering processes within the material the (quasi) free electrons can lose enough energy (thermalize)

before reaching the cathode surface and therefore produce an electron beam with small mean transverse energy [2]. In contrast, higher incident photon energies lead to increased energy spread and to a reduction of the ablation threshold intensity of the photocathode material [3].

This naturally leads to the second important parameter which has to be considered – the laser pulse energy (or to be more precise the number of photons within a laser pulse). By first approximation the number of generated free electrons is proportional to the number of photons. However, space charge shielding effects and depletion of electrons at the surface of the photocathode as well as electron-hole recombination within the material – only to mention a few processes - reduce the quantum yield defined as the number of generated free electrons at the cathode per number of incident photons. At high laser pulse energies the space-charge shielding effect can even lead to saturation (Fig. 1).

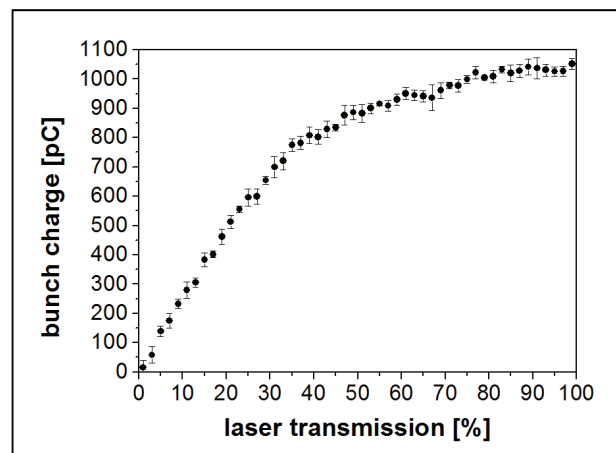

Figure 1: Example of measurement of the electron bunch charge with a Faraday cup as a function of laser energy 80 cm downstream the cathode. The laser energy is given in per cent of the maximum.

High pulse energies combined with high photon energies also risk thermal laser ablation of the photocathode material, which would destroy the characteristics of the photocathode and hence the properties of the electron bunch.

There are two more crucial laser pulse parameters – pulse duration and pulse shape. The latter has to be considered in three dimensions (spatially and temporally).

PREPRESS

Copyright © 2014 CC-BY-3.0 and by the respective authors

ISBN 978-3-95450-133-5

1

\*Work supported by the German Federal Ministry of education and Research, project 05K10CHE “Development and experimental test of a laser system for producing quasi 3D ellipsoidal laser pulses” and RFBR grant 13-02-91323.

<sup>#</sup>Tino.Rublack@desy.de

While the pulse duration defines the electron bunch length the pulse shape defines the electron distribution within the electron bunch – as mentioned earlier, the higher the number of photons at a specific time and position the larger the generated electron density.

### ELECTRON BUNCH OPTIMIZATION

The influence of the laser pulse parameters on electron emission are well known [4], so the next step for cathode laser optimization is the simulation of the optimized electron bunch properties to get maximum brightness and small energy spread.

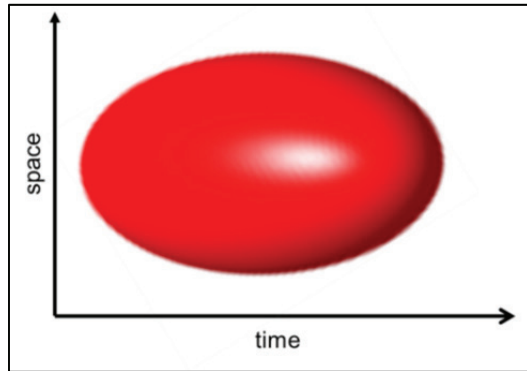

Figure 2: Illustration of a 3-D ellipsoidal laser pulse.

Simulations using PARMELA respectively ASTRA code show that the ideal electron bunch profile is ellipsoidal in both time and space (3-D) [5,6]. To generate such electron bunches the cathode laser beam must also be 3-D ellipsoidal (Fig. 2), assuming a one-to-one correlation between the incident laser pulse and the photocathode emission process. Simulations based on the PITZ photoinjector layout have shown a significant decrease of projected emittance of about 60 % compared to cylindrical Gaussian laser pulses and 32 % compared to cylindrical flat-top laser pulses [7]. A full description of this simulation procedure has been published by Khojoyan et al. [8].

### 3-D ELLIPSOIDAL PHOTOCATHODE LASER SYSTEM

Motivated by the simulations, a laser system capable of producing 3-D ellipsoidal laser pulses is under investigation at IAP / RAS in collaboration with JINR. It is planned to install the laser system at PITZ in autumn this year. The PITZ photoinjector uses an L-band RF gun with a Cs<sub>2</sub>Te photocathode. With a work function of 3.3 eV these cathodes require a laser wavelength in the UV (about 260 nm) [9]. Simulation studies at PITZ show that, depending on the bunch charges, a RMS pulse duration of about 4 – 8 ps and a transverse RMS size of the laser beam between 0.25 and 0.75 mm at the cathode generates very low emittance and at the same time very high peak currents.

The schematic set-up of the laser system is shown in Fig. 3. It consists of a dual-output fiber laser, a diode pumped Yb:KGW disk amplifier, a 3-D pulse shaper, and a frequency conversion unit for second and fourth harmonic generation. A scanning cross-correlator system has also been developed and built for the diagnostic channel to measure the spatial and temporal distribution of the shaped laser pulses.

The dual-output fiber laser generates 1030 nm laser pulses at a repetition rate of 45 MHz. The pulse duration of the laser pulses is about 150 fs. It also comprises a fiber-based pulse stretcher, a preamplifier and a system for pulse train (macropulse) formation. For a precise tuning of the laser pulse timing with respect to the RF phase, which is crucial for optimized operation of the photo injector, a piezo ceramic cylinder has been integrated inside the optical fiber coil of the oscillator.

The laser beam is then split into two beams at the output of the fiber laser – one is used for generation of electrons at the photocathode, after 3-D shaping and frequency conversion, the other one for temporal laser pulse characterization using the cross correlator technique.

After the fiber laser, the pulses of the primary output (working channel) are amplified using a multi-pass (10 passes to date) Yb:KGW disk amplifier. As pump source a LDM 2000-100 (Laserline GmbH) is used. Recently,

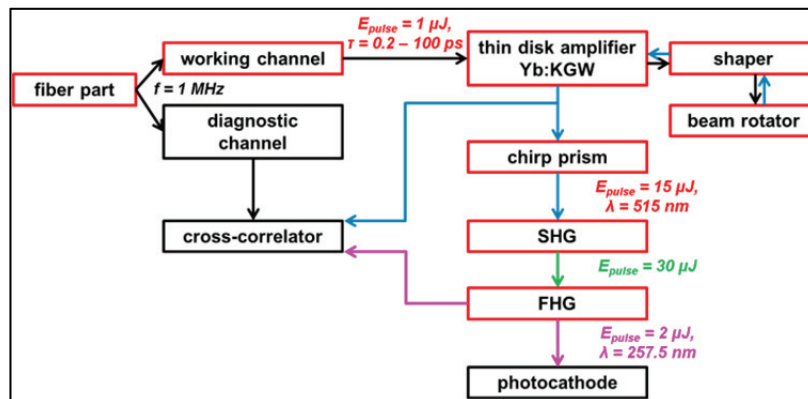

Figure 3: Schematic set-up of the actual 3-D ellipsoidal laser system.

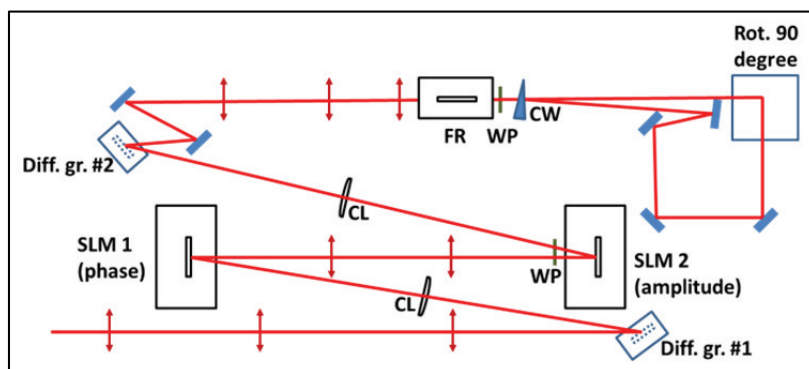

Figure 4: Setup of the 3-D pulse shaper: Diff. gr. – diffraction gratings, SLM – spatial light modulator, WP – half-wave plates, CL – cylindrical lens, FR – Faraday rotator, CW – calcite wedge, Rot. 90 degree – laser beam rotator (90°).

laser pulses up to 120  $\mu\text{J}$  have been obtained. After the multi-pass amplifier the laser pulses are shaped both temporally and spatially. This is realized by a scheme based on two spatial light modulators (currently SLM HES 6010 NIR by Holoeye Photonics AG). The principal set-up of the 3-D pulse shaper is shown in Fig. 4.

The pulse shaper is based on a zero dispersion optical compressor. Among other things, it consists of two diffraction gratings, two cylindrical lenses, two half-wave plates, and two liquid crystal based SLMs. The SLMs are positioned on the focal planes of both cylindrical lenses. So, one diffraction grating is imaged onto the other in the horizontal plane. There is no such imaging in the vertical plane which implies corresponding diffraction. However, these effects can be neglected for the current 3-D pulse shaper set-up, with beam diameter of about 8 mm and focal length of the cylindrical lenses of 405 mm.

The first SLM manipulates the phase of the laser pulse. A half-wave plate installed before the second SLM introduces a 45° rotation of the laser pulse polarization and therefore the second SLM becomes an amplitude manipulator. As one single pass through the pulse shaper only forms the laser profile in one, the laser pulses are passing the set-up twice – in the second pass, the laser pulses are rotated by 90°.

After the pulse shaper a LBO and a BBO crystal are used, respectively, for second and forth harmonic generation.

A cross-correlation with the beam from the diagnostics channel is used to characterize the laser pulses before and after higher harmonic generation. For this, a high-speed delay line is implemented, which allows measurement of the spatial and temporal profile of the laser pulses with high precision [10]. A full description of the cross-correlator can be found elsewhere [7].

## CONCLUSION

Simulations have shown that 3-D ellipsoidal laser pulses instead of cylindrical pulses with Gaussian or flat-top temporal profiles can significantly reduce the emittance of electron bunches generated by a photoinjector. On the basis of these simulations a laser system capable to create 3-D ellipsoidal laser pulses is

under development. Thereby a description of the actual set-up and the principal procedure of pulse shaping have been given.

## REFERENCES

- [1] R.A. Powell et al., “Photoemission Studies of Caesium Telluride”, *Phys. Rev. B*, 8(8), p. 3987 (1973).
- [2] S. Karkare et al., “Monte Carlo charge transport and photoemission from negative electron affinity GaAs photocathodes”, *J. Appl. Phys.* 113, p. 104904 (2013).
- [3] T. Rublack et al., “Laser ablation mechanism of transparent layers on semiconductors with ultrashort laser pulses”, *Proc. SPIE 8190, Laser-Induced Damage in Optical Materials*, Boulder, USA, 2011.
- [4] E.M. Logothetis and P.L. Hartman, “Laser-Induced Electron Emission from Solids: Many-Photon Photoelectric Effects and Thermionic Emission”, *Phys. Rev.* 187, p. 460 (1969).
- [5] C. Limborg-Deprey and P.R. Bolton, “Optimum electron distribution for space charge dominated beams in photoinjectors”, *Nuclear Instruments and Methods in Physics Research*, A557, p. 106 (2006).
- [6] M. Khojayan et al., “Beam dynamics optimization for the high brightness PITZ photo injector using 3D ellipsoidal cathode laser pulses”, TUPSO36, *Proc. 35th International Free Electron Laser Conference*, Manhattan, USA, 2013.
- [7] T. Rublack et al., “Development of a quasi 3-D ellipsoidal photo cathode laser system for PITZ”, WEPRO055, *IPAC’14, Dresden, Germany* (2014).
- [8] M. Khojayan et al., “Studies on the Application of the 3D Ellipsoidal Cathode Laser Pulses at PITZ”, THPRO043, *IPAC’14, Dresden, Germany* (2014).
- [9] S. Schreiber et al., “Photocathodes at FLASH”, *Proceedings 3rd Int. Particle Accelerator Conf.*, p. 625, New Orleans, USA, 2012.
- [10] V. V Zelenogorskii et al., “Scanning cross-correlator for monitoring uniform 3D ellipsoidal laser beams”, *Quantum Electron* 44(1), p. 76 (2014).

PREPRESS

Copyright © 2014 CC-BY-3.0 and by the respective authors