

RECENT UPGRADE OF THE PITZ FACILITY*

J. W. Bähr¹, H. Al-Juboori, A. Donat, U. Gensch, H.-J. Grabosch, L. Hakobyan, M. Hänel, R. Heller, Y. Ivanisenko, L. Jachmann, M. A. Khojoyan, G. Klemz, W. Köhler, G. Koss, M. Krasilnikov, A. Kretzschmann, H. Leich, M. Mahgoub, J. Meißner, D. Melkumyan, M. Otevel, M. Penno, B. Petrosyan, M. Pohl, S. Rimjaem, C. Rüger, M. Sachwitz, B. Schöneich, J. Schultze, A. Shapovalov, F. Stephan, M. Tanha, G. Trowitzsch, G. Vashchenko, L. V. Vu, T. Walther,[†]

A. Brinkmann, K. Flöttmann, W. Gerdau, S. Lederer, L. Lilje, F. Obier, D. Reschke, S. Schreiber, DESY, Hamburg, Germany,

J. Saisut, C. Thongbai, Chiang Mai University and Thailand Center of Excellence in Physics, Thailand

J. Knobloch, D. Richter, Helmholtz-Zentrum Berlin für Materialien und Energie GmbH; Berlin, Germany

P. Michelato, L. Monaco, C. Pagani, D. Sertore, INFN / LASA, Segrate MI, Italy

G. Asova, I. Bonev, L. Staykov, I. Tsakov, INRNE Sofia, Bulgaria

W. Sandner, I. Will, MBI Berlin, Germany

A. Naboka, V. Paramonov, RAS / INR Moscow, Russia

B. L. Militsyn, B. Muratori, STFC / DL / ASTeC, Daresbury, United Kingdom

M. Korostelev, The Cockcroft Institute, Daresbury Laboratory, Warrington, United Kingdom

T. Vilaithong, Thailand Center of Excellence in Physics, Thailand

W. Ackermann, W. F. O. Müller, S. Schnepf, T. Weiland, TEMF, TU Darmstadt, Darmstadt, Germany

I. Ullmann, Universität Erlangen, Erlangen, Germany

J. Rönsch-Schulenburg, J. Rossbach, Universität Hamburg, Hamburg, Germany

* Supported by : EU contract: IASFS RII-CT-2004-506008

¹ Corresponding author: J. Bähr: juergen.baehr@desy.de

Abstract

The Photo Injector Test facility at DESY, Zeuthen site (PITZ), is dedicated to develop and optimize high brightness electron sources for short wavelength Free-Electron Lasers (FELs) like FLASH and the European XFEL, both in Hamburg (Germany). Since October 2009 a major upgrade is ongoing with the goal to improve the accelerating components, the photocathode drive laser system and the beam diagnostics as well. The essential new feature in the running will be an in-vacuum 10 MW RF directional coupler to be used for the RF monitoring and control. In this context a significant improvement of the RF stability is expected. RF pulses of 800

microseconds with 10 Hz repetition rate will be used. The most important upgrade of the diagnostics system will be the implementation of a phase space tomography module (PST) consisting of three FODO cells each surrounded by two screen stations. The goal is an improved measurement of the transverse phase space at different charge levels. The upgraded facility will be described.

INTRODUCTION

High brightness electron sources for short wavelength Free Electron Lasers (FEL) are being developed and optimized at the Photo Injector Test facility at DESY, Zeuthen site [1]. In the recent running break major

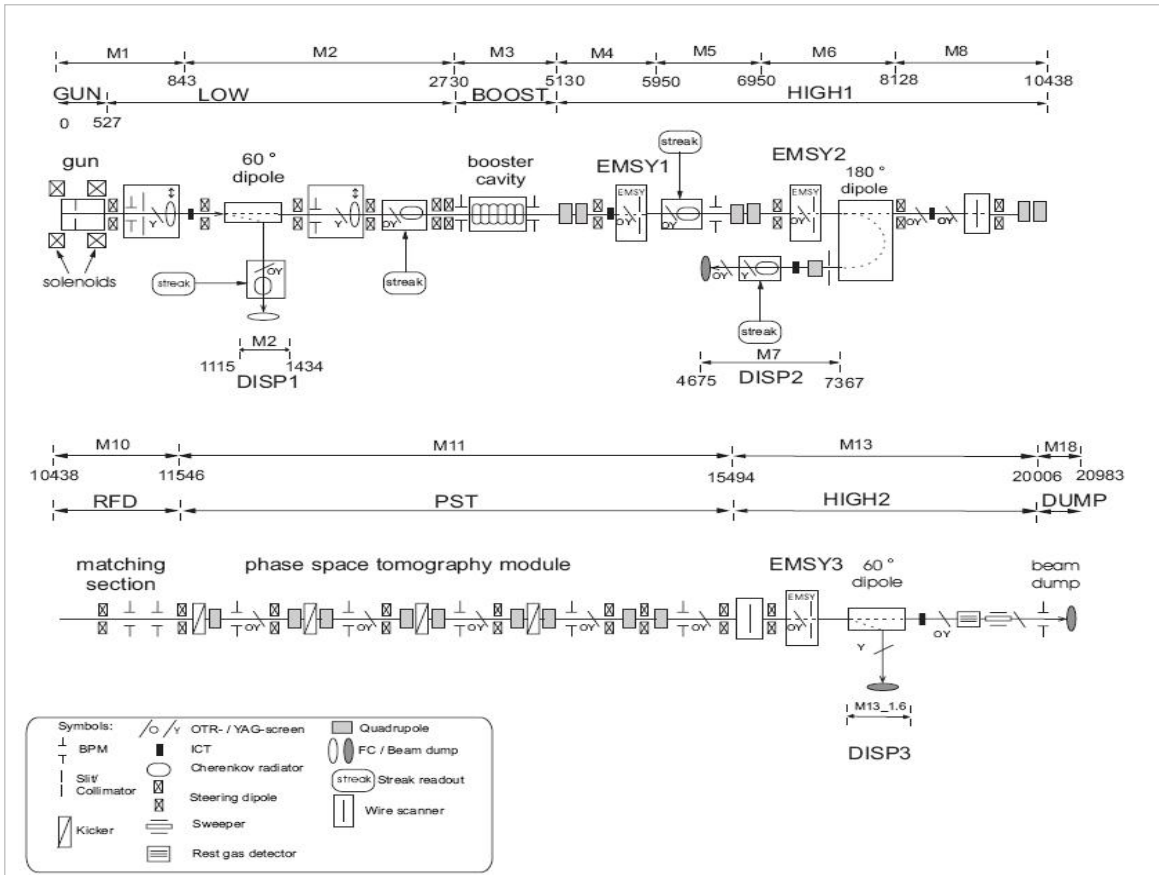

Fig.1 Schematic of the upgraded PITZ facility

components are being replaced or newly installed. The major items of this upgrade are the exchange of the electron gun, the exchange of the booster cavity and the installation of a phase space tomography module. The schematic of the upgraded facility is shown in Fig.1. A gun of the same type as the previous one is installed now in PITZ. The conditioning has started and the gun will be characterized in 2010. Currently, a peak RF power of 2.7 MW was reached during gun conditioning.

NEW 10 MW IN-VACUUM RF COUPLER

In the previous PITZ setup [2] signals from 2 directional couplers (5 MW each) have been used to control the RF power in the gun cavity. This setup implies ceramic vacuum windows after each coupler and a T-combiner to mix both waves and feed them into the gun cavity. A possible cross-talk of both directional couplers and uncertainty in the gun cavity response complicated significantly the operation of the LLRF system. The feed-back loop became extremely complex, non-reliable and could not be used for the beam measurements. This resulted in large gun phase fluctuations since only the RF feed-forward has been applied [3].

To improve the control on the RF in the new PITZ gun (gun prototype 4.1) a newly developed 10-MW in-vacuum directional coupler has been installed [4] after the T-combiner. The main advantage of its usage compared to

the previous RF feeding scheme is a direct control on the combined forward wave and on the wave reflected from the gun cavity. First signals from antennas of the 10-MW in-vacuum directional coupler are shown in Fig.2, where the amplitude (power) and the phase of gun forward and reflected pulses are presented. After the upgrade of the RF system, the optimization of the phase shifter position located in one of two arms of the 10-MW klystron became more straightforward. It is reduced to the maximization of the gun forward power amplitude while the gun is being kept close to the resonance temperature. Preliminary studies on the possibility of feedback loop implementation have been done at a power level of ~0.3 MW and different gun resonance temperatures. The feed-back applied at these conditions resulted in an improvement of the gun phase stability by a factor of about 3. Preliminary measurements of the RF phase jitter of the vector sum with a closed feed back loop yielded the RMS value of ~0.2 deg. More detailed studies on LLRF regulation are foreseen when the nominal RF power in the gun cavity (~7 MW) will be achieved.

THE NEW BOOSTER CAVITY

A new booster cavity based on a Cut Disk Structure (CDS) was developed and will be mounted at PITZ in spring 2010 [5]. The booster cavity will have an improved cooling system. It will be able to accelerate electrons above 20 MeV/c and will be suitable for long bunch

trains. The booster cavity is under preparation to be inserted in the beam line of PITZ.

The photo injector arrangement is a full metal system and operates in the ultra high vacuum range. The residual gas should be free of hydrocarbons and the contribution to the total pressure of oxygen or oxygen containing gases should be negligible. Otherwise, one would get an oxidation or

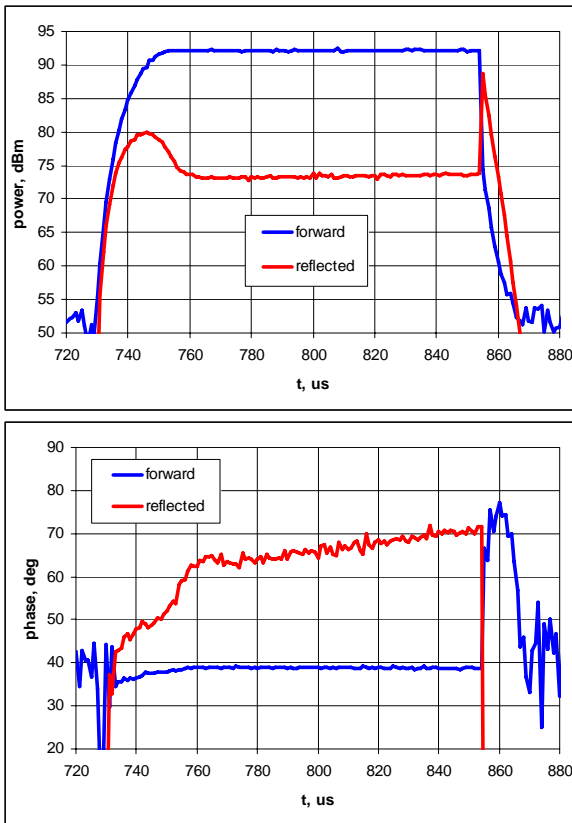

Fig.2. Signals from 10-MW in-vacuum coupler - forward and reflected RF pulses. RF power in dBm (upper Fig.) and the phase along the RF pulse (below) have been measured at the power level of ~ 1.6 MW for the pulse length of $100 \mu\text{s}$. No feed-back has been used for this measurement.

poisoning of the photo cathode and consequently reducing its life time. Presently, a vacuum conditioning of the booster is running to reduce the out-gassing rate. It is done by baking at a separated test arrangement. After that, the booster will be installed at PITZ whereby the pumping will start using turbo molecular pumps. Later an ion getter pump arrangement supplemented by titanium sublimation pumps will allow stable RF conditions.

THE PHASE SPACE TOMOGRAPHY MODULE

The module consists of three FODO cells, whereby pairs are separated by a screen station. The number of screens, namely four, has been chosen in order to obey the requirement for as much as possible projections used for

the reconstruction. The tomography theory proposes equidistant angular steps between each two projections, wherefrom the phase advance between two adjacent screens is 45 degrees. It has been shown in [5] that such a phase advance delivers the smallest emittance measurement discrepancy using a multi-screen method with four screens. An upstream cell with identical geometry can be used as well to increase the number of projections.

The desired systematic uncertainty of the measured emittance is below 10 %. This corresponds to a relative deviation of the measured spot size on a screen of 10 %. As the geometry of the module is rather compact with short but strong focusing quadrupole magnets, the 10 % deviation of the spot size sets tight requirements on the mechanical alignment of the components. Those are given in the table 1 below:

Table 1: Components mounting tolerances in rms values .

Misalignment	Value	Units
Longitudinal quadrupole off-set	0.1	μm
Quadrupole roll angle	10	mrad
Quadrupole pitch angle	20	mrad
Quadrupole yaw angle	20	mrad
Longitudinal screen off-set	0.1	μm
Screen rotation around x- and y- axes	10	mrad

The positioning of the screen stations and quadrupoles is done by means of a laser tracker and a hexapod, see Fig.3: Five of those screen stations and eleven quadrupoles have to be installed in the module.

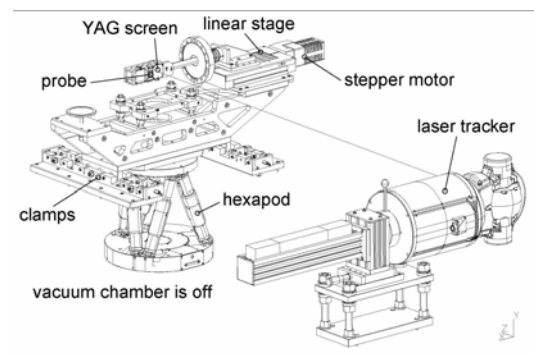

Fig. 3: The alignment of a screen station of the tomography section by means of a laser tracker and a hexapod.

IONIZATION PROFILE MONITOR

An Ionization Profile Monitor (IPM) [7] will be inserted in the rear part of the beam line, in the first step only for one projection of the beam profile. One of the advantages of such a device is the possibility to work at high bunch charge and long bunch trains.

The IPM consists of an electrode, called the “Repeller plate”, and a high spatial resolution detector (MCP). Both components have a definite potential. Additional electrodes are installed to provide an uniform electrical field between the Repeller plate and the MCP, see Fig 4.

The residual gas inside the beam tube is ionized by the electron beam. The produced ions are accelerated in a homogeneous electrical field toward the MCP. After amplification inside the MCP, electrons hit a phosphor screen. A CCD camera records the phosphorescence to a computer for further evaluation.

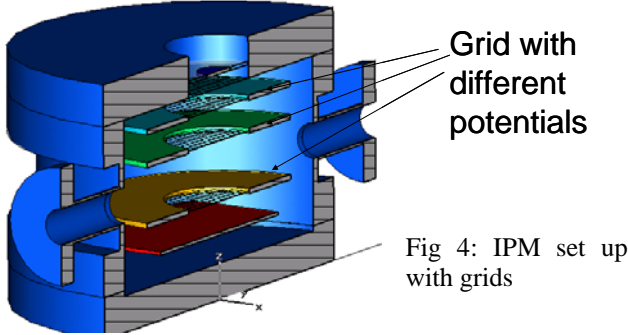

LASER SYSTEM

For generation of flat-top pulses an Yb:YAG laser system is used. This laser generates long pulse trains that contain up to 800 individual “micropulses” in the train. A flat-top shape of the individual pulses of the train is accomplished by means of a multicrystal birefringent filter [8]. In this filter, the flat-top pulse shape is obtained by stacking several replicas of the input pulse, where the number of replicas is by one larger than the number of crystals used. The temperature of the individual crystals is precisely controlled in such a manner that the light field of the neighbouring replicas of the input pulse interfere constructively. High-quality flat-top pulses with rising and falling edges of approx. 2 ps duration are generated this way. In contrast to other arrangements [9,10], the produced pulses exhibit a precisely linear polarisation, which allows to further amplify them in a diode-pumped Yb:YAG amplifier chain and convert them to the fourth harmonics ($\lambda = 257.5$ nm) while maintaining the flat-top shape.

The duration of the pulses emerging from the birefringent filter depends on the effective number of crystals in it. Changing the pulse shape is accomplished by appropriately rotating the birefringent crystals in the shaper. Figure 5 shows the flat-top pulses of approximately 23.4 ps duration (FWHM) generated by using thirteen 2.7 mm thick YVO_4 crystals in the shaper following further amplification in Yb:YAG amplifier stages and after conversion to the fourth harmonics. An innovation of the laser beam line is the integration of a gated intensified CCD camera. A fraction of the UV laser beam propagating from the laser to the photo injector is split off and directed onto a fast intensified CCD camera. The shape of the UV pulse was measured by cross-correlating it with a second femtosecond infrared pulse. Alike the photocathode, this camera is also located at an image position of the aperture that is used for generating the spatial flat-top profile. By selecting an exposure time of approximately 500 ns as well as an appropriate trigger it is possible to measure the spatial intensity distribution for each laser bunch within the pulse train. These images

will be used to extract position, size and intensity of the UV laser beam as well as their variations within the pulse train. A first example of such a measurement is shown in Fig. 6.

The air conditioning in the laser room was improved with the goal to minimize oscillations of the temperature. The maximum temperature oscillation is now ± 0.1 degree as specified.

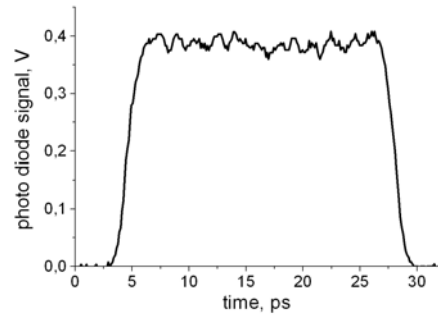

Fig. 5: Flat-top UV pulse of 23 ps duration produced by the photo injector drive laser at PITZ.

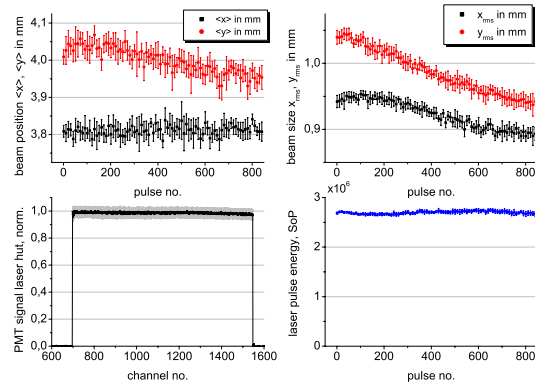

Fig. 6: Variation of beam position (upper left), beam size (upper right) and laser pulse energy (lower right) during a train of 850 laser bunches derived from the signal of the gated, intensified CCD camera. For comparison, the UV pulse energy as observed using a photomultiplier (PMT) on the laser table is also depicted (lower left).

THE BEAM INHIBIT SYSTEM (BIS)

The BIS is an independent hardware, which protects parts of the system from destruction due to false operation. The logic is processed by a Siemens SPS S7-300 [10].

The communication with the control system is realized via Ethernet UDP protocol. The BIS detects the state of magnets, vacuum valves, screens, cathode, shutters, Emittance Measurement Systems (EMSYs) and Faraday cups to define maximum pulse length for the klystron, charge and numbers of laser pulse. The operating modes can be predefined or are self-detected from the state of the facility.

TV SYSTEM – CAMERA TESTS

The following cameras were tested in the lab:

- JAI (CCD): TM-2040, BM-141 [12].
- Prosilica (CCD): GC-13050, GC-1380, GE-1380 [13]
- PhotonFocus (CMOS): D1312-80, D1312-40 [14]

All cameras have a GigE interface. The Prosilica GC-1350 was measured each time as a reference camera. The main criteria the comparison are sensitivity of the camera, shutter speed, signal to noise ratio and radiation hardness. The camera measurements procedure can be divided in two parts:

- taking frames for different gain levels with closed cap, so called dark frame
- taking frames for different gain levels from the object which was illuminated by a lamp.

The first measurement gives a noise distribution in the camera itself.

Also some other important features like gain range, possibility to adjust the black level, shutter control were studied. All cameras except PhotonFocus series have a possibility to control the gain at range approximately up to 24 dB. All cameras except PhotonFocus series and JAI TM-2040 have good noise distribution, mean and rms values. Unfortunately all Prosilica series have automatic black level control and look up tables made in such a way that they cut in a part of the signal. All the cameras have a good controllable shutter speed with a minimum shutter time of about 10 μ s. A radiation hardness test is foreseen in the near future. The summary plots are shown in the figures 7 and 8. To summarize we can say that the JAI BM-141 is the best choice for our measurements.

CONCLUSION

A major upgrade of the PITZ facility is ongoing. The electron gun is exchanged and under commissioning. A new accelerating booster cavity is under preparation to be installed in the beam line. The upgrade of the beam diagnostics is ongoing mainly by installation of the phase space tomography module. The complete restart is assumed in summer 2010.

REFERENCES

- [1] F.Stephan et al., Photo Injector Test Facility and Construction at DESY, FEL 2000, Durham.
- [2] F.Stephan et al., Detailed characterization of electron sources at PITZ, yielding first demonstration of European X-ray Free-Electron Laser beam quality, Phys.Rev. Special Topics-Acc. And beams, 13, 020704, (2010)
- [3] F.Stephan, M.Krasilnikov, "High Brightness Beam Measurements at PITZ", talk at Workshop on the physics and applications of high brightness electron beams, Maui, Hawaii, 16-19.11.2009, <http://pbpl.physics.ucla.edu/HBEB/>.
- [4] MEGA Industries, H28 Sanford Drive, Gorham, ME 04038

[5] V.V. Paramonov et al., Design Parameters of the Normal Conducting Booster cavity for the PITZ-2 Test Stand.

[6] G. Asova et al., Phase space tomography diagnostics at the PITZ facility, Proceedings ICAP 2006, Chamonix, France

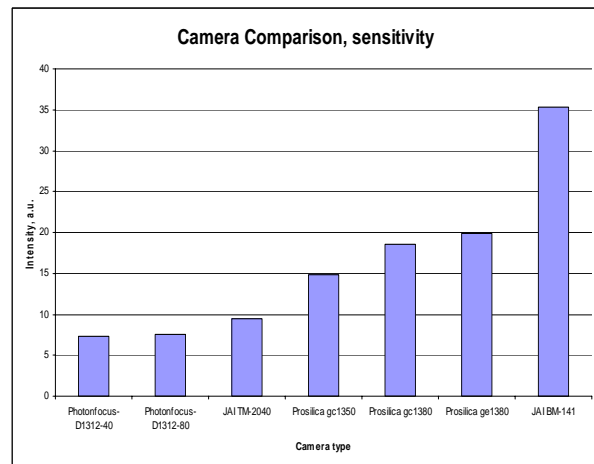

Fig. 7: CCD camera comparison: Sensitivity in arbitrary units

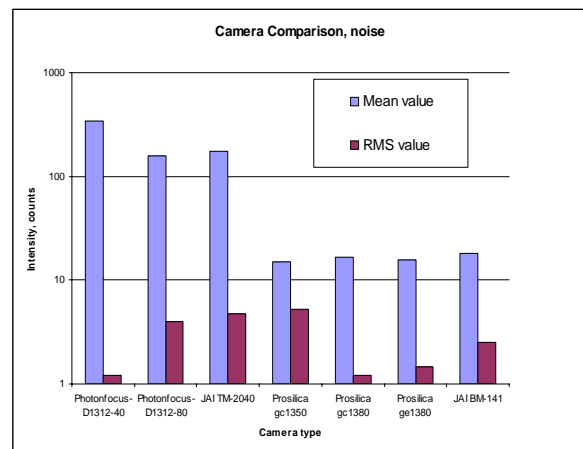

Fig. 8: CCD camera comparison: noise in counts

[7] A. Hofmann et. al., EPAC2008, Genoa

[8] I.Will, G.Klemz, Generation of flat-top picosecond pulses by coherent pulse stacking in a multicrystal birefringent filter, Opt. Express 16, 14922 (2008).

[9] S. Zhou, et al., Efficient temporal shaping of ultrashort pulses with birefringent crystals, Appl. Opt. 46, 8488-8492 (2007).

[10] I. Bazarov et al., Efficient temporal shaping of electron distributions for high-brightness photoemission electron guns, Physical Review ST – Accel. Beams 11, 040702 (2008).

[10] <http://www.automation.siemens.com>

[12] <http://www.jai.com/>

[13] <http://www.prosilica.com/>

[14] <http://www.photonfocus.com/>