

Low energy high brilliance beam characterization

J. Bähr, DESY, Zeuthen, Germany

Abstract

Low energy high brilliance beam characterization plays an important role for electron sources and injectors of Free Electron Lasers (FELs) and electron linear accelerators as for example the future ILC project. The topic is discussed basing on solutions of the PITZ facility (Photo Injector Test facility Zeuthen) which are compared with methods applied at other facilities. The properties of an electron beam produced at a laser driven rf-gun is mainly influenced by characteristics of the laser beam and the electron gun itself. Therefore aspects of diagnostics will be discussed for the laser, laser beam line and gun as well. The main properties of the electron beam are transverse and longitudinal phase space and emitted charge. Measurement of transverse beam size and position, transverse emittance, charge and longitudinal phase space will be discussed in detail. At PITZ the measurement of the longitudinal phase space is based on a correlated measurement of the momentum spectrum and the temporal characteristics of the electron bunch.

INTRODUCTION

Low energy high brilliance beam characterization will be discussed at the example of PITZ (Photo Injector Test facility Zeuthen) [1] at DESY. PITZ is a dedicated facility for the optimization of electron sources for FELs. The energy range of PITZ1 (until fall 2004) was 4.5 MeV, the energy range of PITZ2 [2] just under commissioning will increase to 30 MeV in 2005-2006. The nominal bunch charge is 1 nC. The discussion of the characterization will cover mainly the transversal phase space, the longitudinal phase space and charge as well. Further diagnostics topics as the characterization of processes at the cathode and in the electron gun, the relative phase between laser and rf and properties of the photocathode laser beam will be discussed shortly as well. Further examples of

diagnostics of other facilities will be discussed in the momentum range up to 130 MeV/c. The production and characterization of polarized beams is not matter of this paper.

PITZ

The sketch of the beam line of PITZ1 is shown in fig. 1. The facility consisted of three sections: the cathode section, the gun section and the diagnostics section. PITZ1 was dismantled in the beginning of 2005. The upgrade, PITZ2, is under commissioning now and will be completed in several steps until end of 2006. Fig. 2 shows schematic of the beam line of PITZ2.

The electron source of PITZ is a normal conducting 1.5 cell laser-driven rf-cavity. The rf-frequency is 1.3 GHz. The active cover of the photo cathode is Cesium Telluride. Main topics of the upgrade for PITZ2, are the use of a booster cavity to demonstrate the emittance conservation principle [3] and the increase of the field gradient in the gun to improve the electron emittance from the beginning. The diagnostics beam line will be essentially extended.

TRANSVERSE PHASE SPACE

Beam size and beam position

The characterization of beam position and beam size is a standard task at every particle accelerator. There are invasive and non-invasive devices in use:

- Fluorescence screens (e.g. YAG)
- Optical Transition Radiation (OTR) screens
- Beam position monitors (BPM)
- Wire scanners

The YAG (Yttrium-Aluminium garnet) transforms part of the beam energy in visible light. This light is usually imaged on the sensor of a TV-camera. Two kinds of YAG

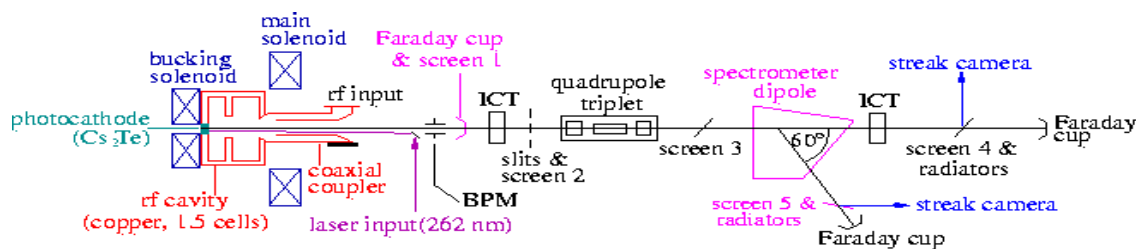

Figure 1: Schematic of PITZ 1.

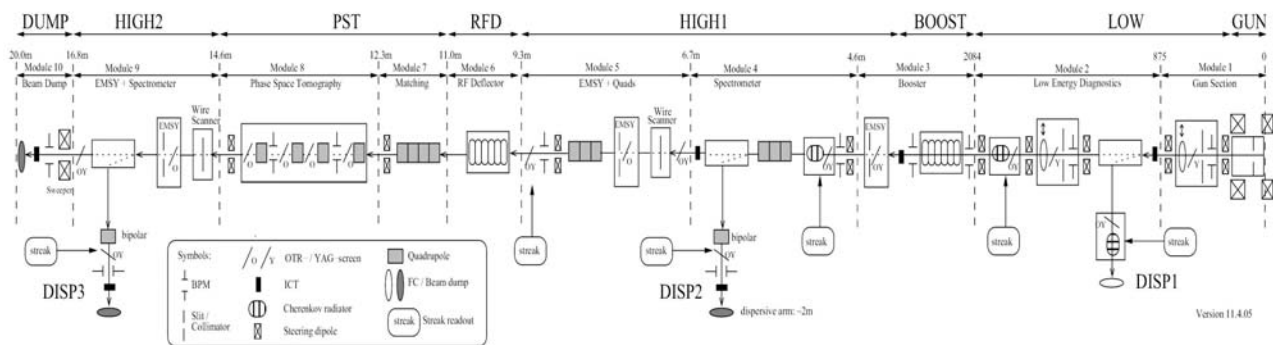

Figure2: Schematic of PITZ2

are commonly in use, polycrystalline and Cerium-doped mono-crystals.

Several kinds of TV-cameras and optical systems are applied at the various facilities. CCD type cameras are mostly chosen. Analogous and digital read-out modes are distinguished. At PITZ [4] an analogous camera with non-interlaced read-out, external trigger and remotely controlled gain is applied. The optical scheme of the TV system is optimized such, that the camera does not need to stay near to the beam line. One of the major problems is the low radiation hardness of common CCD-cameras. At PITZ the cameras are shielded by lead bricks. The TV systems contain an illumination for the screens, and a calibration unit. Using a movable mirror a calibration grid is imaged onto the camera sensor. Magnification and resolution can be measured and calibrated.

OTR screens are based on the effect of Optical Transition Radiation (OTR). The charged particle beam causes a light cone emitted from a metallic screen. Examples for such screens are aluminium coated capton or aluminium coated Silicon. The half angle of the emission cone is the inverse of the relativistic γ -factor. Therefore there is a lower threshold for the use of OTR. OTR is commonly used for electron energy > 10 MeV.

Beam position monitors (BPM) are based on an antenna principle. Their use is widely discussed on DIPAC conferences (for example DIPAC 2001, [5] and others). Therefore it will not be discussed in this paper.

Wire scanners [6] are used for the measurement of the beam diameter, halo and position. A thin wire (O(50 microns) is moving fast through the particle beam. A system of scintillation detectors is detecting part of the created gamma quanta. By measuring the signals of several scintillation detectors and measuring the position of the wire accurately at the same time the beam profile and position can be reconstructed. A wire scanner for one coordinate was used in PITZ1. Two wire scanners with a two-coordinate measuring system will be used at PITZ2. Several wire scanner stations are in use at the VUV-FEL at DESY [7].

Measurement of transverse emittance

The measurement of the transverse emittance will be discussed using three examples:

- EMSY [8] at PITZ
- The emittance-meter at SPARC [9]
- A 4-screen method at the VUV-FEL [10]

At PITZ1 and PITZ2 the transverse emittance is measured using the Emittance Measurement System (EMSY). The apparatus contains several tungsten masks (single slit, multi-slit, pepper pot) which can be moved in four degrees of freedom (two transverse, two rotational). The electron beam hits the masks and most of the beam is scattered. But also undisturbed beam-lets are produced. The beam-lets are analyzed using a YAG screen in a distance of about 1 m, see fig.3. The transversal beam

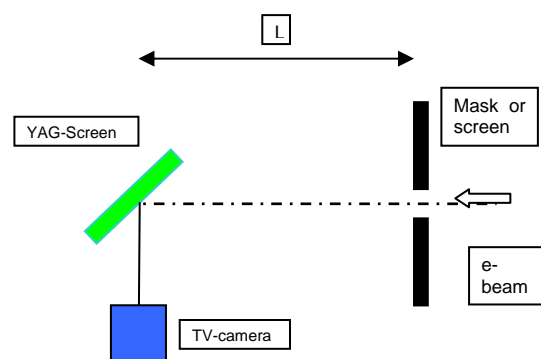

Figure 3: Schematic of emittance measurement

distribution is also measured in the plane of the masks. Fig. 4 shows an example of results of autumn 2004 [11].

At SPARC an emittance meter is under commissioning. The goal of this device is the coordinate dependent measurement of the transverse emittance in a range of about 1.5m along the beam direction, see fig.5. It is foreseen to do a first commissioning of this device with beam measurement at PITZ.

The transverse emittance at the VUV-FEL was measured recently at 130 MeV based on a 4-screen method. The

four quadrupoles are situated behind the first bunch compressor. The readout is realized using OTR-screens.

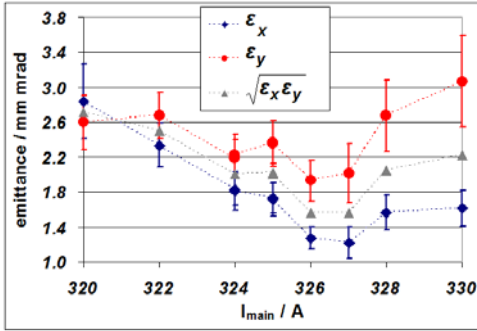

Figure 4: Emittance results vs. solenoid current

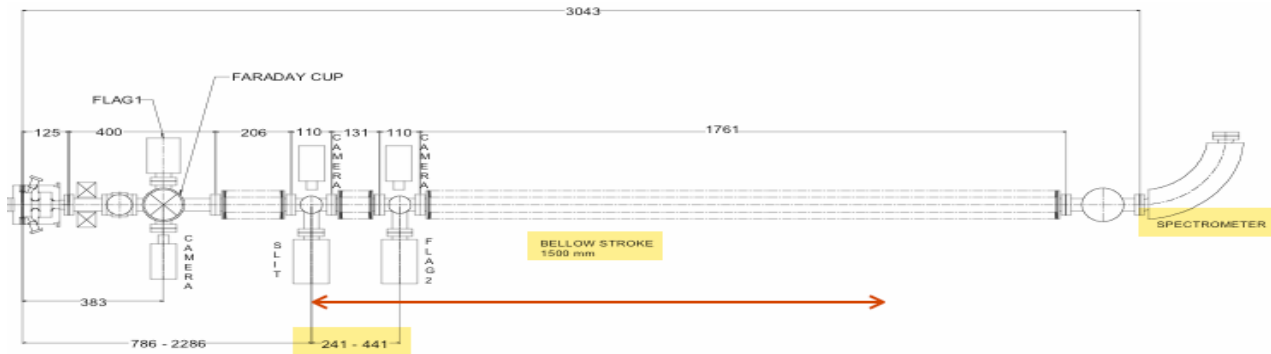

Figure 5: Emittance meter from the SPARC collaboration

LONGITUDINAL PHASE SPACE

The longitudinal phase space is spanned by the momentum, the bunch length. Besides the properties also the correlation between these properties is important. The measurement of the beam momentum is usually realized in magnet spectrometers using dipole magnets. A special case of a 180-degree spectrometer will be used at PITZ2 and at the ELBE facility [12] in the near future. They have several advantages what can be easily derived by analyzing the transport matrix of the dipole [13]:

- Influence of divergence at entrance of the dipole is zero
- Dispersion is maximized resulting in optimum resolution
- The resolution is independent of transverse emittance
- Space economy
- No turning of image needed for streak camera readout.

Measurement of the complete longitudinal phase space

A measurement of the complete longitudinal phase space was performed at PITZ. This includes a measurement of the momentum spectrum and the bunch length as well as their correlation. Fig. 6 shows the principle of the measurement [14]. The measurement of the bunch length at PITZ is performed using a streak camera [15]. The electron beam hits a Cherenkov radiator. The best light output compared to OTR and a quartz plate was reached using Silica aerogel (refractive index 1.03 and 1.05) as Cherenkov radiator. The light is transmitted by a 27 m long optical transmission line [16]. It is mainly constructed of telescopes consisting of achromatic lenses. The bunch length measurement is possible for the uncorrelated case in the straight section and for the correlated measurement in the magnet spectrometer. For the correlated measurement the light distribution representing the momentum spectrum has to be imaged exactly onto the entrance slit of the streak camera. The

dimensions of the image have to fit to both slit dimension, the image has to be focussed into the slit plane and to be parallel to the slit.

One example of the results of the measurements for 1nC bunch charge and a temporal flat top laser pulse is shown in table 1[17]. For all 4 properties the results of the measurements agree with the simulation within the error range.

Table 1: Results of long. phase space measurement

	measured	Astra
FWHM / ps	SS: 25.2 +/- 1.3; DA: 28.5 +/- 3.3	25
long. emittance / π keV mm	32.7 +/- 6.8	26,6
momentum / MeV	5.19 +/- 0.06	5,19
momentum spread / keV	46.0 +/- 5.1	42,2

A deflecting cavity for the measurement of single bunches is used at the VUV-FEL at DESY in Hamburg. The device of 3.6 m length is part of a DESY-SLAC collaboration and a contribution of SLAC [18]. The goal

is to reach a time resolution of about 10 fs. The principle sketch is shown in fig.7. A pre-selected bunch gets a kick by the rf-field of 25 MV and 18 MW. The transverse kick is 40 microns in the plane of a screen. The created light distribution is imaged onto a camera sensor. Similar devices are foreseen for example at SPARC and PITZ2.

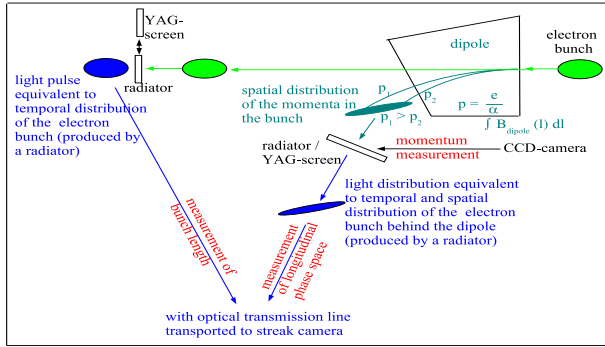

Figure 6: Schematic of measurement of longitudinal phase space

Electro-optical sampling

The refractive index of electro-optical crystals (for example ZnTe) can be changed by the electric field of the electron bunch. Such a crystal can be mounted inside the

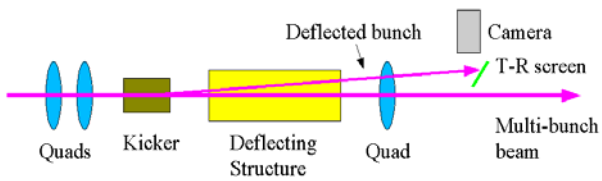

Figure 7: Deflecting rf-cavity at VUV-FEL

beam pipe near to the electron beam. The read-out is realized by a laser beam (for example Ti:Sa) with short pulse length (< 1 ps). Different schemes of optical analysis are published [19]. The reached resolution is about 100 fs.

CHARGE AND CURRENT

Charge and current of single bunches and bunch trains can be measured by Faraday cups, integrating current transformers (ICT) and wall gap monitors. These techniques are well known and will be not discussed widely in this paper. Faraday cups are sensitive down to charges of about 1 pC whereas the sensitivity threshold of commercially available ICTs measured at PITZ is about 100 pC.

PROCESSES AT CATHODE AND RF-GUN

The gun cavity at PITZ is a 1.5 cell normal conducting copper cavity running at 1.3 GHz. A proper tuning of the eigen-frequency of the cavity has to be guaranteed for stable running with stable gradient. The fine tuning of the gun is realized by a powerful cooling system which controls the gun temperature on the level of 0.1 degree water temperature.

Dark current is a phenomenon which can limit the performance of an injector or accelerator essentially. One main source is field emission at the cathode, at the gun corpus or at cutures of the cathode fixing mechanics. Investigations of the dark current are described in [20].

The photo cathodes at PITZ are produced at INFN Milano [21]. The sensitive cathode substance is Cesium Telluride. The quantum efficiency QE and its temporal behavior is an essential quality factor of an electron source. Cesium Telluride is very sensitive to vacuum, therefore a high vacuum of about $>10^{-10}$ mbar has to be maintained in the gun cavity. The measurement of the quantum efficiency is done by two methods at PITZ. The first method is in-situ. The extracted charge created by a laser pulse of known pulse energy is measured. The second method is based on a dedicated setup consisting of a high pressure mercury lamp and a pico-amperemeter. The light intensity is measured absolutely. A typical QE of freshly produced cathodes is about 10 percent. During operation it decreases down to about 1 percent.

PHASE

The phase between rf-system and the photocathode laser is an essential property of every laser driven rf-gun. The behavior of the gun shows several characteristic points varying the phase over the active range of about 100 degrees, for example the phase of maximum mean energy gain and the phase of maximum charge.

At PITZ three methods of phase measurements are applied [22]. The first is the usual phase scan. The phase is varied over the full range and the charge is measured. Both other methods are in use to measure the phase of the maximum mean energy gain. This can be done by measuring the momentum of the particles in the bunch using the spectrometer. Alternatively the phase of highest energy is estimated by measuring the electron beam diameter on a YAG screen as function of the phase. It has been shown [23] that the phase of the maximum mean energy gain is very close to a maximum or minimum of the beam diameter depending on the setting of the focussing solenoid.

LASER

The photo cathode laser is one of the deciding sub-systems of a laser-driven rf-gun determining to a large extent the quality of the electron beam. The photo cathode laser of PITZ is developed by the

Max-Born-Institute Berlin [24]. Flat-top laser pulse profiles in time and space are necessary to reach the needed low transverse beam emittance. Furthermore, the stability of several parameters like laser pulse energy and phase has to be guaranteed. Therefore, dedicated diagnostics tools have to be provided. The transverse beam profile (see fig.7) is monitored by two virtual cathodes, working in different

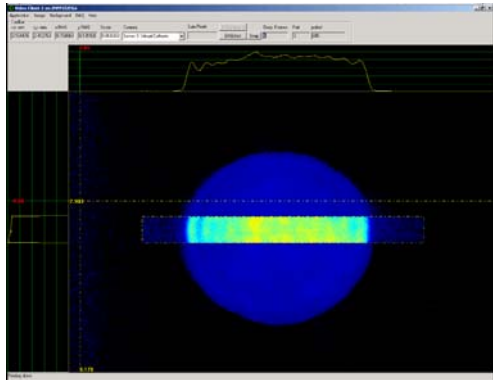

Figure 7: Transverse laser beam profile

ranges of laser pulse train energy. These virtual cathodes are realized by CCD-cameras which are UV sensitive and in a position corresponding to the photo cathode in the gun. The laser pulse energy monitoring by photomultiplier is under commissioning at PITZ. The monitoring of direction, position and transverse profile of the laser beam for PITZ will be realized by a TV system. It is in preparation on the laser table and will be realized by two cameras for the near and far field. The longitudinal laser pulse profile is monitored using a streak camera.

CONCLUSION

An overview about methods of diagnostics for low energy high brilliance electron beams is presented based on the diagnostics scheme of the PITZ facility and facilities in further accelerator centers.

ACKNOWLEDGEMENT

I want to thank my colleagues of the PITZ collaboration for their support, especially J.Roensch, S.Khodyachykh, V.Miltchev and F.Stephan for fruitful discussions.

REFERENCES

- [1] F.Stephan et al., Proc. FEL2000, Durham
- [2] A.Oppelt et al., Linac 2004 Lübeck
- [3] M.Ferrario et al., LNF-00-004(P)
- [4] J.Bähr et al., DIPAC 2001, Grenoble
- [5] L.Farvacque et al., DIPAC2001,Grenoble
- [6] A.B.El-Sisi, DIPAC2003, Mainz, p.131
- [7] M.Sachwitz et al., DIPAC2005, Lyon
- [8] K.Abrahamyan et al., DIPAC 2003 Mainz, p.225
- [9] D.Alesini et al., "Virtual beam dynamics experiments at SPARC, ICFA workshop 2005, Zeuthen
- [10] K.Honkavaara et al., Measurements of Transverse Emittance at TTF VUV-FEL, ICFA workshop 2005, Zeuthen
- [11] L. Staykov et al., DIPAC 2005, Lyon
- [12] Th.Kamps, ICFA workshop 2005, Zeuthen
- [13] S.Khodyachykh, Internal paper, PITZ 2005
- [14] J.Rönsch, Diploma Thesis, Univ. of Hamburg 2005
- [15] D.Lipka, PhD Thesis, Berlin 2004
- [16] J. Bähr et al., DIPAC 2003, Mainz, p.98
- [17] J.Rönsch, "Measurement of the Longitudinal Phase Space at the Photo Injector Test Facility at DESY in Zeuthen (PITZ) DIPAC 2005, Lyon
- [18] C.O'Connell et al., "Bunch Longitudinal Profile Diagnostics using a Transverse Deflection cavity (LOLA) at the TTF", ICFA workshop 2005, Zeuthen
- [19] Berden et al., DIPAC 2003, Mainz, p.25
- [20] J.H.Han et al., PAC 2005, Knoxville
- [21] D.Sertore et al., Proc.EPAC 2004, p.408
- [22] M.Krasilnikov, PAC2005, Knoxville
- [23] M.Krasilnikov, PAC2005, Knoxville
- [24] I.Will et al., Nucl. Instr. Meth. A472(2001), p.79

