

RECENT RESULTS AND PERSPECTIVES OF THE LOW EMITTANCE PHOTO INJECTOR AT PITZ

F. Stephan[#], K. Abrahamyan[&], G. Asova[§], J. Bähr, G. Dimitrov[§], U. Gensch, H.-J. Grabosch, J.H. Han, M. Krasilnikov, D. Lipka, V. Miltchev, A. Oppelt, B. Petrossyan, D. Pose, S. Riemann, L. Staykov, DESY, 15738 Zeuthen, Germany

M.v. Hartrott, E. Jaeschke, D. Krämer, D. Richter, BESSY, 12489 Berlin, Germany

I. Bohnet, J.P. Carneiro, K. Flöttmann, S. Schreiber, DESY, 22603 Hamburg, Germany

J. Roßbach, Hamburg University, 22761 Hamburg, Germany

P. Michelato, L. Monaco, C. Pagani, D. Sertore, INFN Milano, 20090 Segrate, Italy

I. Tsakov, INRNE, 1784 Sofia, Bulgaria

W. Sandner, I. Will, Max-Born-Institute, 12489 Berlin, Germany

W. Ackermann, W.F.O. Müller, S. Schnepf, S. Setzer, T. Weiland, TU Darmstadt, 64289 Darmstadt, Germany

Abstract

The Photo Injector Test Facility at Zeuthen (PITZ) was built to study the production of minimum transverse emittance electron beams for Free Electron Lasers and future Linear Colliders. Until November 2003, the electron beam from the rf gun has been fully characterized at PITZ. For a bunch charge of 1 nC a minimum normalized projected beam emittance of 1.5π mm mrad in the vertical plane and a minimum geometrical average of both transverse planes of 1.7π mm mrad have been achieved. This fulfills the requirements of the VUV-FEL at DESY. In this contribution, an overview of the measured electron beam and high duty cycle rf parameters including transverse emittance, thermal emittance, bunch length, momentum, and momentum spread will be given. In addition, planned major upgrades and first results towards fulfilling the even more challenging requirements for the European XFEL will be discussed. This includes measurements with increased average and peak rf power and the improvement of the transverse laser beam profile.

INTRODUCTION AND LAYOUT

The successful operation of short wavelength SASE FELs requires electron sources providing high phase space densities. For the case of the VUV-FEL at TTF2 in Hamburg, a normalized transverse projected emittance at the undulator entrance of about 3π mm mrad at 1.5 kA peak current is needed for saturation at about 30 nm and 2π mm mrad at 2.5 kA peak current is needed for saturation at 6 nm, in both cases assuming a rms energy spread of 1 MeV [1]. For the XFEL, even more demanding parameters are requested: for a charge of 1 nC a projected normalized emittance of 1.4π mm mrad is needed at the undulator entrance which corresponds to an emittance of about 0.9π mm mrad at the injector exit [2, 3]. For the development of such electron sources the PITZ

facility was built. After the decision to build the facility at Zeuthen was taken in September 1999, the civil construction happened in 2000 and in 2001 the necessary hardware components were installed. In January 2002, the first photoelectrons were produced and the facility was continuously upgraded. In November 2003, the first cavity installed at PITZ was fully characterized, fulfilling the VUV-FEL parameter requirements. The experimental results obtained with this cavity (called prototype #2 because it was the second rf gun cavity produced at DESY) will be summarized in the first half of this paper. Since January 2004 this cavity has been installed at the VUV-FEL at TTF2 in Hamburg and went smoothly into operation [4].

After moving the prototype #2 to Hamburg, the older gun cavity prototype #1 was installed at PITZ. Although we knew several shortcomings of this cavity beforehand (limited surface quality, problems with bulk copper material, for more details see [5]), it is suited to study the high average power behavior of the rf gun. Those measurements together with electron beam dynamics studies will be summarized in the second half of this paper. Beyond this, the R&D program necessary to reach the XFEL requirements will be shortly described.

The experimental set-up used for the measurements with gun prototypes #2 and #1 has essentially been identical and is shown in Figure 1. It consists of a 1.5 cell L-band rf gun with a Cs₂Te photo-cathode, a solenoid system for compensating space charge induced emittance growth, a photo-cathode laser system capable of generating long pulse trains with variable temporal and spatial micro pulse shape, and an extensive diagnostics section.

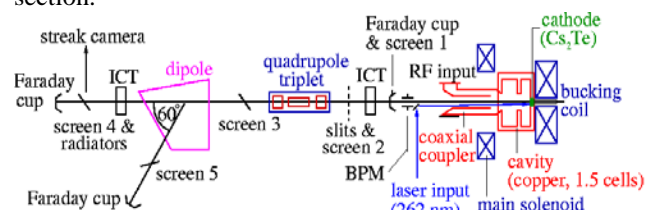

Figure 1: Layout of PITZ.

[#] frank.stephan@desy.de

[&] on leave from YERPHI, 375036 Yerevan, Armenia.

[§] on leave from INRNE, 1784 Sofia, Bulgaria.

LASER PARAMETERS

The laser system operated at PITZ was developed at the Max-Born-Institute (MBI) in Berlin. Its schematic layout is shown in Figure 2. The system produces laser pulse trains up to 800 μs length with a repetition rate of up to 5 Hz and a single pulse repetition rate of 1 MHz.

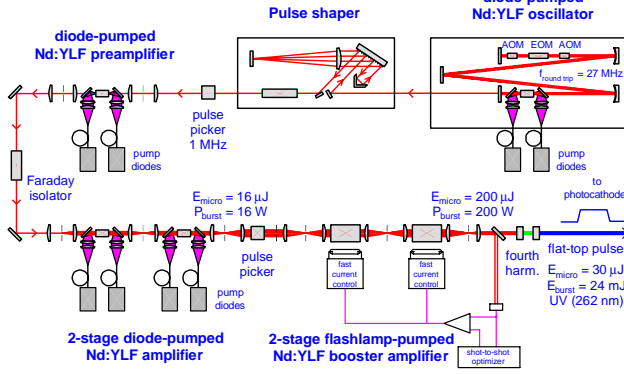

Figure 2: Layout of the PITZ laser system.

The temporal and transverse properties of the individual laser pulses on the photo-cathode play a major role in obtaining a good electron beam quality. Therefore, those parameters are regularly monitored using a streak camera for the temporal laser profile and a CCD camera at a position equivalent to the photo-cathode location (virtual cathode) for the transverse laser shape. Typical distributions for the optimized laser settings obtained during the operation of gun cavity prototype #2 at PITZ are shown in Figure 3. It is obvious that the transverse profile is not the desired flat-top distribution but more close to a truncated Gaussian with some modulations.

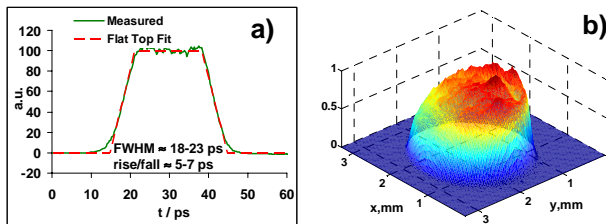

Figure 3: Typical a) temporal and b) transverse laser profile used for the operation of gun cavity prototype #2. The temporal profile was measured at a wavelength of 524 nm. The transverse rms beam size on the cathode was 0.51 mm for x and 0.63 mm for y.

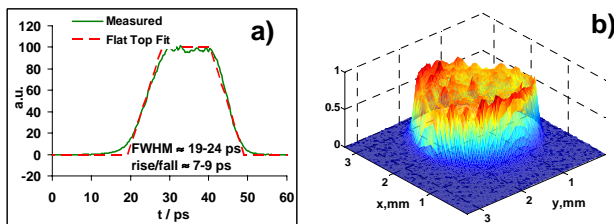

Figure 4: Typical a) temporal and b) transverse laser profile used for the operation of gun cavity prototype #1. The temporal profile was measured at a wavelength of 262 nm. The transverse rms beam size on the cathode was about 0.58 mm in x and in y.

To improve the transverse laser profile on the photo-cathode the laser beam transport line was re-designed and put into operation in June 2004. The laser parameters for the beam dynamics measurements with the gun cavity prototype #1 are shown in Figure 4. Now, the transverse shape is close to a flat-top profile, but modulations are still visible.

CHARACTERISATION OF THE RF GUN FOR THE VUV-FEL AT TTF2

Achieved RF Parameters

A smooth conditioning procedure of the gun cavity prototype #2 yielded an operation with rf pulses of up to 900 μs length, a repetition rate of 10 Hz, and a peak rf power of about 3 MW. This corresponds to a duty cycle of 0.9 % and about 27 kW average power in the cavity. Since the field strength on the cathode is 11% higher than in the full cell for gun prototype #2, an accelerating gradient of about 42 MV/m was obtained on the cathode.

Normalized Transverse Emittance

After the entire beam diagnostics had been put into reliable operation an experimental optimization procedure was started [6]. During the parameter scans it turned out that the mirror in the vacuum system, which deflects the laser beam onto the photo-cathode, was affecting the beam quality [6, 7]. After the beam was steered horizontally around the vacuum mirror and a fine adjustment of the laser parameters was done (result is shown in Figure 3), a minimum normalized projected emittance of $1.5 \pi \text{ mm mrad}$ was obtained in the vertical plane and a minimum geometrical average of both transverse planes of $1.7 \pi \text{ mm mrad}$ was achieved, see Figure 5. Details of the emittance measurement procedure are described in reference [8]. These results agree with simulations, fulfill the requirements of the VUV-FEL, and were confirmed several times in different weeks and by different shift crews.

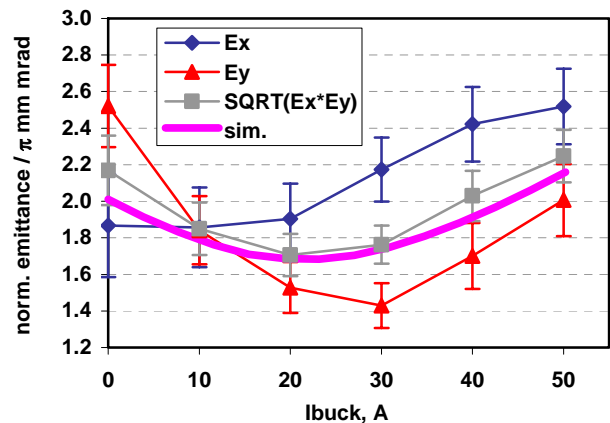

Figure 5: Projected normalized transverse emittance for gun cavity prototype #2 as a function of bucking solenoid current which is used to compensate the magnetic field on the photo-cathode. The rf phase is 5 degrees lower than the phase with maximum mean energy gain, the main

solenoid current is 305 A, and the charge is 1 nC. The fat line shows an ASTRA simulation [9] of the geometrical average using input parameters as described in the previous sections.

Momentum and Momentum Spread

Using the dipole and screen 5 the momentum distribution was measured [10]. The mean momentum and the momentum spread are shown in Figure 6. The error bars come from the uncertainties in the dipole field and the mechanical alignment as well as from the non-zero beam size and divergence at the dipole entrance. Good agreement between measurement and simulation is obtained.

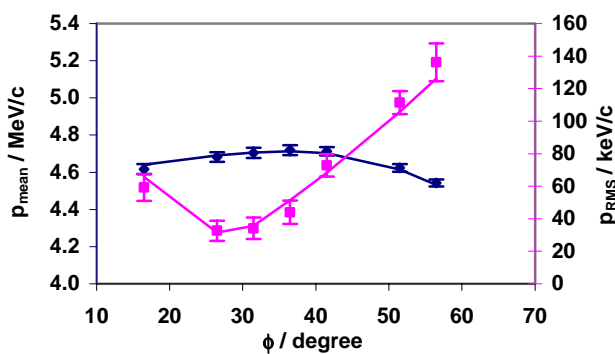

Figure 6: Mean momentum (blue) and momentum spread (magenta) as a function of rf phase for gun cavity prototype #2. The points are the measurements and the line represents the corresponding ASTRA simulation. The emitted charge was tuned to be 1 nC for each of the measurement points. The laser settings used correspond to Figure 3.

Bunch Length

The electron bunch length was measured using silica aerogel as Cherenkov radiator, an optical transmission line, and a streak camera [10]. A minimum bunch length of 21ps FWHM was measured at the same phase where the momentum spread is minimum. The minimum bunch length is about 3 ps shorter than the emitting laser pulse used at that time.

MEASUREMENTS WITH THE NEXT RF GUN AT ZEUTHEN

Achieved RF Parameters

When the older cavity prototype #1 was installed at PITZ in the beginning of 2004, the main goal was to condition it up to the maximum rf power available from the 5 MW klystron installed [11]. The maximum peak power was reached with about 4 MW in the gun cavity. A maximum average power of 30 kW was obtained on July 8th (1000 μ s, 10 Hz, 3 MW), limited by the available water-cooling system. Its upgrade was already scheduled for Dec. '04 to Feb. '05. Nevertheless, the cavity has been operated stable with rf pulse lengths of up to 1300 μ s and full peak power at 5 Hz repetition rate, see Figure 7.

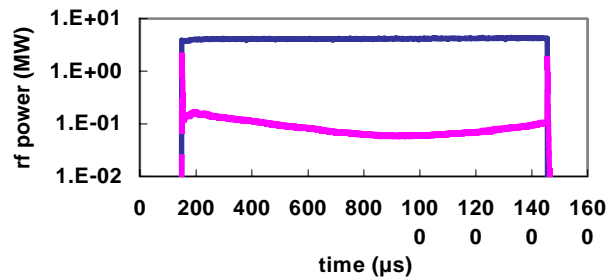

Figure 7: Forward power and reflected power from the gun cavity prototype #1 operated at 5 Hz.

Normalized Transverse Emittance

With the increased rf input power and the improved transverse laser profile the emittance has been re-measured [8]. The current status of optimization is shown in Figure 8. The main error contribution comes from the background subtraction. Although the optimization is still in progress, the minimum emittance in one plane and the minimum geometrical average are about the same or slightly better than the year before. One obvious difference is that the emittances in x and y do not cross over for different bucking coil currents anymore. This can be explained by the difference in the transverse laser beam profile (compare Fig. 3 and Fig. 4 and the laser beam sizes on the cathode). Further optimization will include measurements at different transverse laser spot sizes.

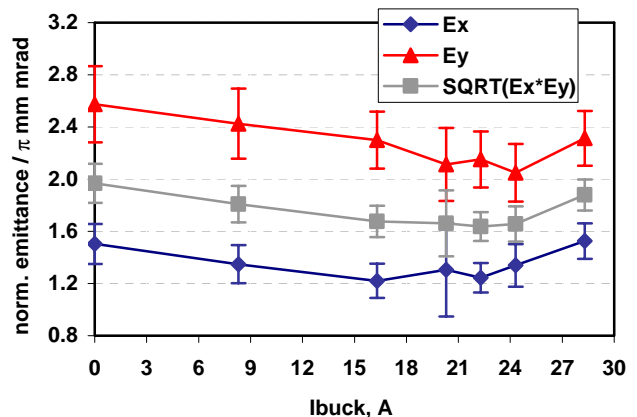

Figure 8: Preliminary measurement of the projected normalized transverse emittance for gun cavity prototype #1 as a function of bucking solenoid current. The rf phase is 5 degrees lower than the phase with maximum mean energy gain, the main solenoid current is 326 A, and the charge is 1 nC.

Thermal Emittance

Measurements for estimating the thermal emittance from Cs₂Te cathodes have been done with gun cavity prototypes #2 and #1. Details are described in reference [8]. Average kinetic energies between 0.7 eV and 0.9 eV have been obtained with different cathodes and different measurement procedures. For a rms laser spot size on the cathode of 0.55 mm this corresponds to a thermal emittance of about 0.6 π mm mrad.

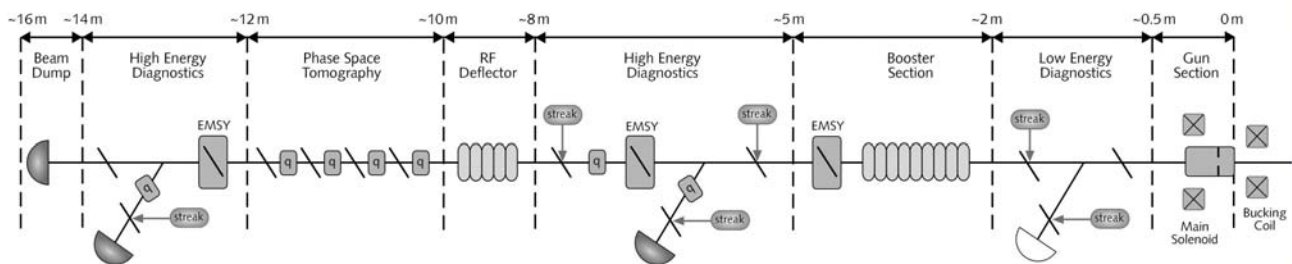

Figure 10: Simplified schematic layout of the PITZ2 set-up. The beam goes from right to left.

Momentum and Momentum Spread

With the increased rf power in gun cavity prototype #1, the momentum distribution was re-measured. The mean momentum and the momentum spread are shown in Figure 9. The error sources are the same as mentioned before. Compared to the operation with lower rf input power, the minimum momentum spread is now reduced by about a factor 2 and the phase difference between minimum momentum spread and maximum mean momentum is reduced to about 5 degrees.

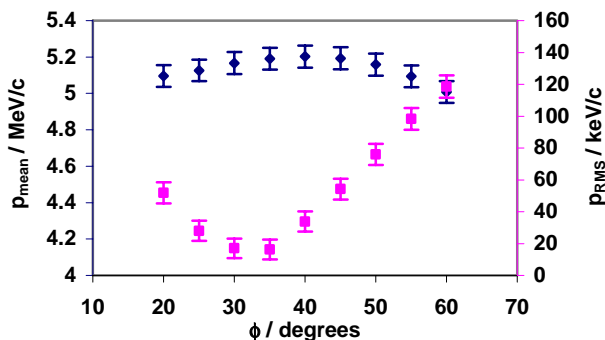

Figure 9: Measured mean momentum (blue) and momentum spread (magenta) as a function of rf phase for gun cavity prototype #1. The emitted charge was tuned to be 1 nC for each of the measurement points. The used laser settings correspond to Figure 4.

R&D PROGRAM TOWARDS THE XFEL REQUIREMENTS

To reach the very demanding requirements for the XFEL mentioned in the introduction, a second phase of PITZ was started (called PITZ2), which is a large extension of the facility and its research program. The work will go into two directions: a) further improve the emittance from the rf gun and b) study the principle for conserving small emittance up to higher beam energy. To reach the required emittance from the rf gun the accelerating gradient at the cathode needs to be increased to ~ 60 MV/m, the rise and decay time in the temporal laser intensity profile of individual pulses has to be reduced to ~ 2 ps, and the transverse laser profile must be further improved. For studying the emittance conservation principle, a booster cavity will be installed and the beam diagnostics section will be upgraded (for details see [12]). A schematic layout of PITZ2 is shown in Figure 10.

SUMMARY

The rf gun for the VUV-FEL at TTF2 was optimized at PITZ. An overview on the results was presented, yielding a minimum projected emittance in the vertical plane of 1.5π mm mrad. Experimental results of the next rf gun cavity installed at PITZ were summarized as well, demonstrating a reliable operation at increased peak and average rf power. Although the optimization procedure for this cavity is not yet finished, very promising results are already obtained. The future plans at PITZ were briefly described.

REFERENCES

- [1] K. Flöttmann and Ph. Piot, "An Upgraded Injector for the TTF FEL - User Facility", EPAC'02, Paris, June 2002.
- [2] For a list of beam parameters of the XFEL linac see http://xfel.desy.de/content/e159/e160/index_eng.html
- [3] Ph. Piot et. al., "Conceptual Design of the XFEL Photoinjector", TESLA FEL report 2001-03, February 2001.
- [4] S. Schreiber for the VUV-FEL group, "Commissioning of the VUV-FEL Injector at TTF", EPAC'04, Lucerne, July 2004.
- [5] J.H. Han et. al., "Conditioning and High Power Test of the RF Guns at PITZ", EPAC'04, Lucerne, July 2004.
- [6] M. Krasilnikov et. al., "Optimizing the PITZ Electron Source for the VUV-FEL", EPAC'04, Lucerne, July 2004.
- [7] S. Setzer et. al., "Influence of Beam Tube Obstacles on the Emittance of the PITZ Photoinjector", EPAC'04, Lucerne, July 2004.
- [8] V. Miltchev et. al., "Transverse Emittance Measurements at the Photo Injector Test Facility at DESY Zeuthen", (TUPOS09, these proceedings).
- [9] ASTRA manual, <http://www.desy.de/~mpyflo/>
- [10] D. Lipka, PhD thesis, Humboldt University Berlin, May 2004.
- [11] J. Bähr et. al., "High Power Conditioning and Measurements of the Longitudinal Emittance at PITZ", (TUPOS03, these proceedings).
- [12] A. Oppelt et. al., "The Photo Injector Test Facility at DESY Zeuthen: Results of the First Phase", Linac'04, Lübeck, August 2004.